



Address: Galway Technology Centre, Mervue Business Park, Galway
Telephone: +353 91 870708, mob. +353 87 2837810, e-mail: info@leanireland.ie, web site: www.leanireland.ie

Course ID: S10

VALUE STREAM MAPPING (VSM)

Online course: 3 webinars x 4 hours each, practical VSM work & assignments

1. What is this course about?

Value stream mapping (VSM) is a high-level diagnostic tool that provides a foundation for a continuous improvement journey. VSM enables a management team to take a systems approach to increasing customer satisfaction and decreasing the cost of operations along the entire product and service value stream. VSM enables an organisation to set its strategic and tactical direction over a number of years, as well as select and scope the projects that will deliver change.

A VSM workshop is facilitated for each major product or service range on an annual basis during which "one year's worth" of projects is identified to further enhance customer service and process performance. This online course introduces participants to VSM, using online mapping software such as Visio or Minitab Workspace.

This course is offered on an in-company basis only i.e. all candidates are from the one organization for a minimum of 8 and maximum of 12 candidates.

2. What will I achieve?

At the end of this series of online workshops, you will:

- understand the purpose and format of a high-level VSM;
- know how to develop an online detailed current state VSM for product that includes performance quantification in the areas of forecasting, order processing, planning, purchasing, production, quality and distribution.
- know how to develop a physical detailed future state VSM for a product that includes planned performance future performance levels in the areas of forecasting, order processing, planning, purchasing, production, quality and distribution.
- Understand how to develop a list of prioritised issues and action items on which to work on during a one-year period, that will deliver a more robust, lower cost and customer friendly process, and
- Understand the key performance metrics, the achievement of which will help to guarantee consistent delivery of customer value.

In addition, you will have an understanding of a broad range of lean process design tools, each of which adds value to the understanding of process and system performance. This knowledge will enable you to facilitate a VSM workshop with confidence.

See VSM examples in figures 1 and 2 below. Before the course starts, the organisation will select a product on which to work during the course. This is typically a high revenue/growing demand product. In consultation with the course tutor, data in connection with the product parameters, is collected in advance of the workshop.

Following the course, the Lean Ireland tutor will be available online, as required, to answer any follow up questions you may have.

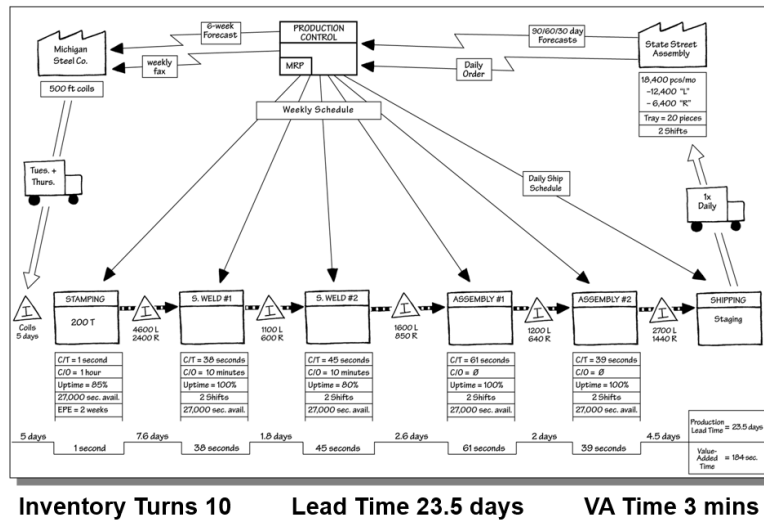

Figure 1. Current state VSM for job shop

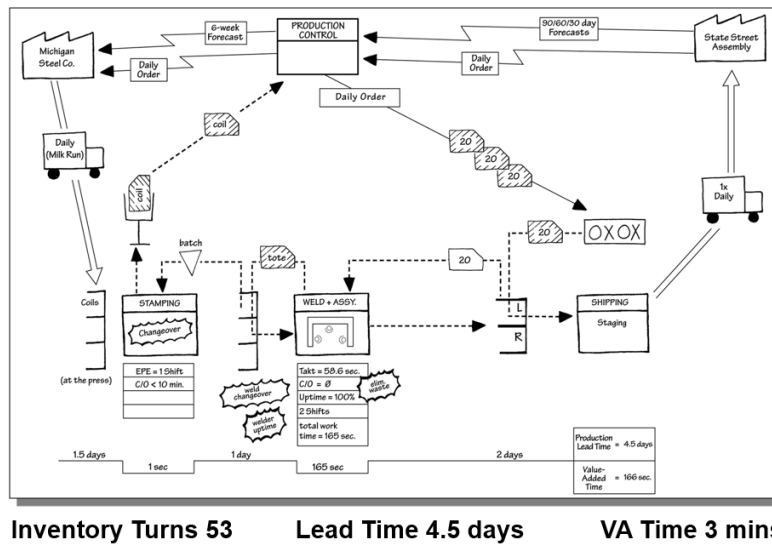

Figure 2. Future state VSM for job shop

(Illustrations courtesy of Rother & Shook, *Learning to See*, Lean Enterprise Institute, Brookline Mass, USA)

3. What topics will be covered?

#	Content (all webinars - 4 hours)	Assignment
S10 S01 Introduction to VSM Architecture of a VSM & Defining Customer Value	<p>Introductions</p> <p>Workflow Principles: Takt Time, the 7 Wastes, closed loop supply chain, cash to cash conversion time, the enterprise view.</p> <p>VSM: Objectives, the role of the sponsor, product/service selection, participants, process & format, deliverables, Q&A, quiz</p> <p>Case study product overview: factors that impact on performance, data collection template, process performance indicators, VSM current state symbols, VSM outline, key interfaces with customer, forecasting, order processing, information flow to site, sales & operations planning, building strategic partnership, Q&A, quiz</p> <p>Assignment</p>	<p>10 Multiple choice questions:</p> <p>Takt time calculations</p> <p>Framework for current state VSM</p> <p>Factors that impact on process performance KPIs</p>
S10 E02 Planning for Success & Product Flow	<p>Assignment review</p> <p>VSM outline: Planning centre, ERP system, workcentre layout and BOM structures, relevance of takt time, MPS/planning cycles, building planning agility.</p> <p>VSM outline: Information flow from site to supplier, forecasting & orders, key interfaces with supplier, inventory management, building strategic partnerships, Q&A, quiz</p> <p>VSM product flow: Information, product & service flow through work centres, level of detail required, the roles of people, performance parameters & units of measure, quantifying performance, adding up the timelines, comparison with ERP data, Q&A, quiz</p> <p>Assignment</p>	<p>10 Multiple choice questions:</p> <p>BOM structure</p> <p>Product planning</p> <p>Inventory management</p>
S10 E05 Facilitation skills C.I. Programme Management	<p>Assignment review</p> <p>Scheduling the workshop, participants & preparation, drawing the current state map, value & non-value add activities, dealing with difficult team members, developing a list of issues, grouping & prioritising issues, Q&A, quiz</p> <p>Selecting projects & assigning responsibilities, project portfolio management, project tracking & reporting, communication plan</p> <p>VSM future state symbols, facilitating the Future State VSM, transforming from push to pull systems, case study review, Q&A, quiz</p> <p>Review & close</p>	<p>10 Multiple choice questions:</p> <p>Identifying VA & NVA activities</p> <p>Project selection</p> <p>Timeline calculations</p> <p>Communication plan</p>

There are 12 contact hours in total. The webinars are hosted on the secure Lean Ireland learning platform.

4. How will I be supported?

During this online course, you will

- be able to listen to and interact with the online course tutor and other participants;
- be able to ask questions and complete online quizzes to self-assess your understanding of the topic;
- be able to download all online course recorded webinars for your own future use, and

- be able to download soft copy presentation files, with data sets and case studies, for your own future use.

Total contact hours = 12 hours for all 3 webinars. In addition to the contact hours on webinars, participants are required to work on small assignments between modules. On completion, you will receive a Lean Ireland certificate of completion.

5. Who is this course for?

This course is designed for senior continuous improvement and senior managers in the organisation. VSM enables an organisation to set its strategic and tactical direction over a number of years, as well as select and scope the projects that will deliver change. As such, a VSM workshop should always be facilitated by an individual who can influence change at a structural and cultural level in the organisation.

6. Where can you find out more?

Please contact Bernie Rushe at Lean Ireland,
Galway Technology Centre, Mervue Business Park, Galway
Telephone: +353 91 870708, mob. +353 87 2837810,
e-mail: info@leanireland.ie, web site: www.leanireland.ie